

## 3.2.90 SPLIT-SHAFT UNIT OUTPUT OPTIONS

### 4 BOLT M12 STUD KIT 2.05.087.0000 FOR 3.2.90.1 / 2 / 3 / 4 / 5 / 6 SPLIT-SHAFT UNIT

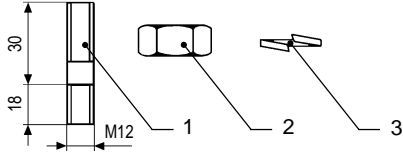

REF.	CODE	DESCRIPTION	QT.
1	0.02.02.031.00	Stud M12x30 UNI 5911	4
2	0.03.01.006.00	Hex nut M12 UNI 5588 CL RES 10	4
3	0.04.08.002.00	Lockwasher 12,5 DIN 7980	4

### MAIN TRANSMISSION FLANGE KITS FOR 3.2.90.1 / 3 / 5 SPLIT-SHAFT UNIT ONLY

#### KIT 2.05.350.0000 SPICER 1500/1600/1700/1800

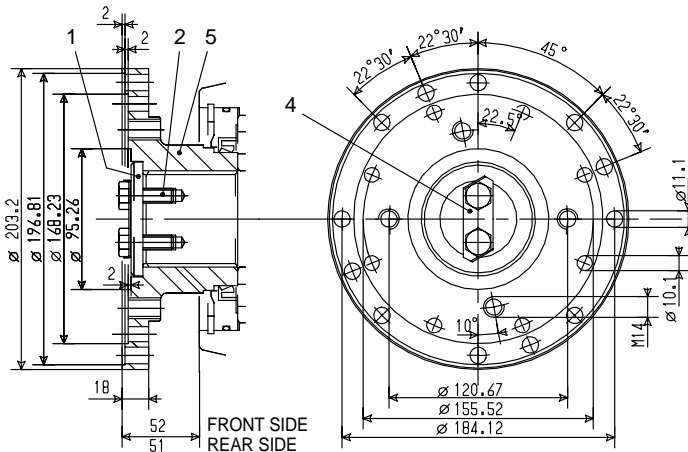

#### KIT 2.05.371.0000 DIN 180

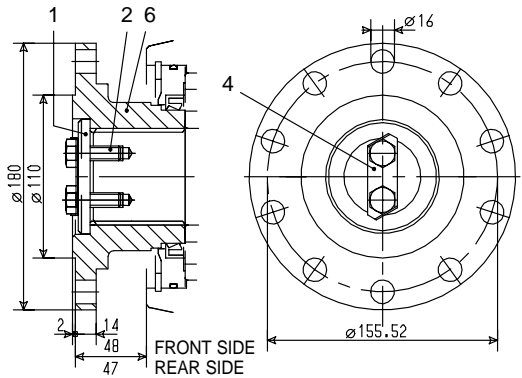

#### KIT 2.05.377.0000 150 ISO 8667

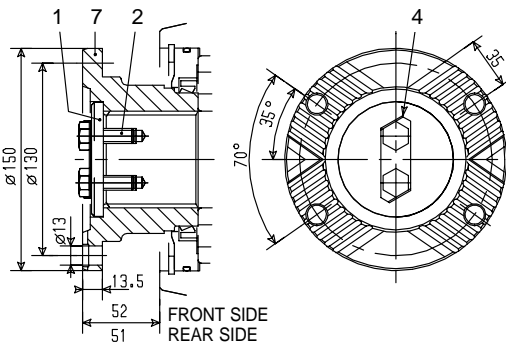

#### KIT 2.05.378.0000 180 ISO 8667

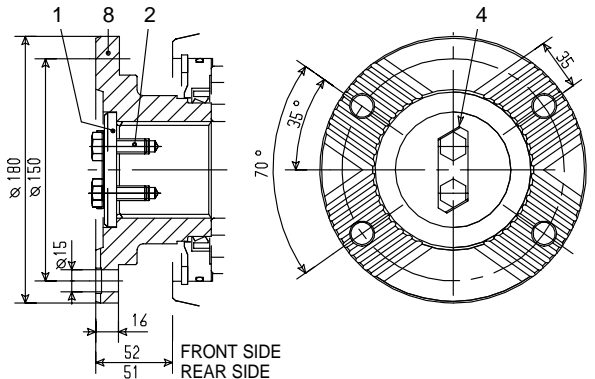

#### KIT 2.05.398.0000 DIN 180 8 fori D14

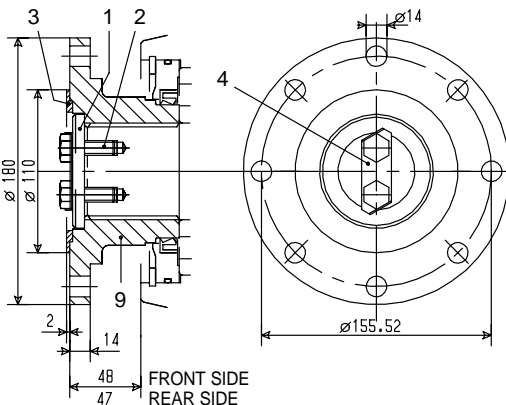

#### KIT 2.05.406.0000 DIN 150

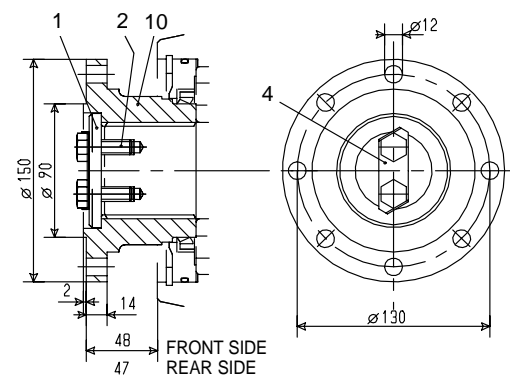

REF.	CODE	DESCRIPTION	QT.
1	1.27.02.124.00	Washer	1
2	0.01.01.014.00	Capscrew TE M10x30 UNI 5739 CL RES 8.8	2
3	1.27.02.140.00	Ring	1
4	1.99.00.244.00	Securing tab	1
5	1.16.04.009.00	Flange SPICER 1500/1600/1700/1800	1

REF.	CODE	DESCRIPTION	QT.
6	1.16.02.021.00	Flange DIN 180	1
7	1.16.05.002.00	Flange 150 ISO 8667	1
8	1.16.05.003.00	Flange 180 ISO 8667	1
9	1.16.02.025.00	Flange DIN 180	1
10	1.16.02.027.00	Flange DIN 150	1

# MAIN TRANSMISSION FLANGE KITS FOR 3.2.90.2 / 4 / 6 SPLIT-SHAFT UNIT ONLY

**KIT 2.05.388.0000 DIN 180**

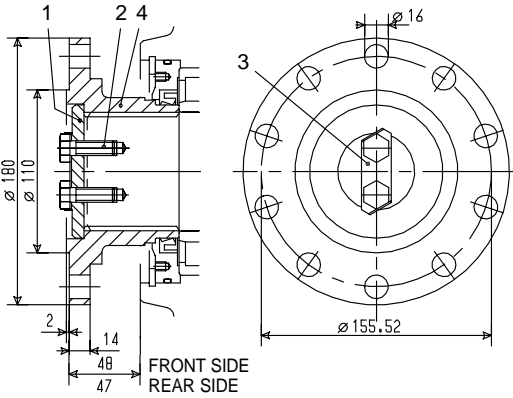

**KIT 2.05.389.0000 180 ISO 8667**

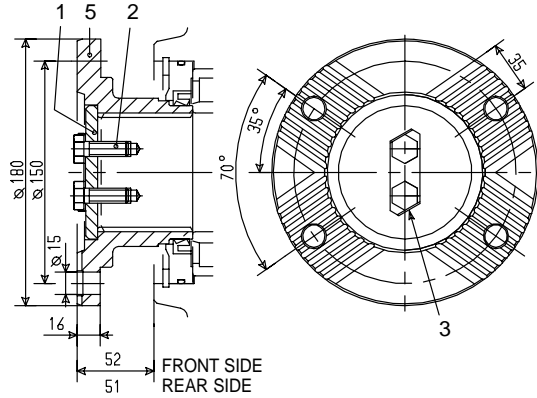

**KIT 2.05.405.0000 SPICER 1600/1700/1800**

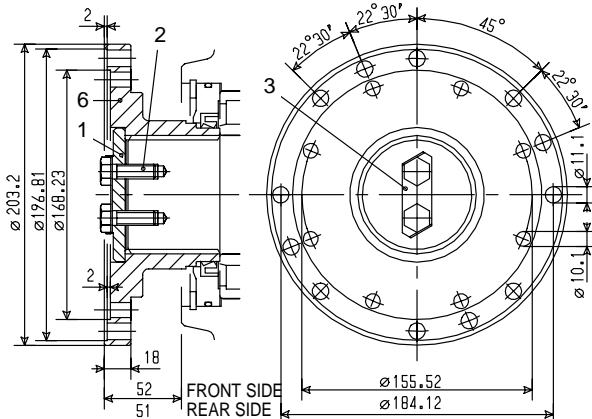

REF.	CODE	DESCRIPTION	QT.
1	1.27.02.138.00	Washer	1
2	0.01.01.014.00	Capscrew TE M10x30 UNI 5739 CL RES 8.8	2
3	1.99.00.244.00	Securing tab	1

REF.	CODE	DESCRIPTION	QT.
4	1.16.02.024.00	Flange DIN 180	1
5	1.16.05.005.00	Flange 180 ISO 8667	1
6	1.16.04.011.00	Flange SPICER 1600/1700/1800	1

# REMOTE TRANSMISSION FLANGE KITS FOR 3.2.90.1 / 2 / 3 / 4 / 5 / 6 SPLIT-SHAFT UNIT

**KIT 2.05.349.0000 SPICER 1410 / DIN 20**

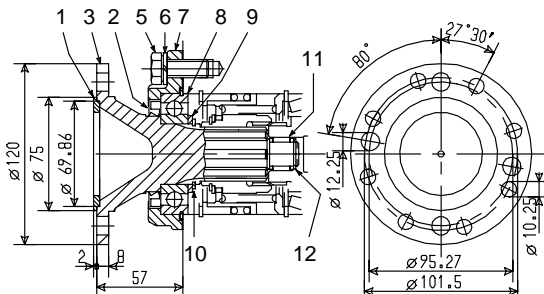

REF.	CODE	DESCRIPTION	QT.
1	1.27.02.123.00	Centering ring	1
2	0.08.01.090.00	Seal 50x72x8 Viton	1
3	1.16.04.012.00	Flange SPICER 1410 / DIN 20	1
4	1.16.01.035.00	Flange SPICER 1500	1
5	0.01.01.010.00	Capscrew TE M12x30 UNI 5739 CL RES 8.8	4
6	0.04.02.004.00	Lockwasher 13 UNI 1751	4

**KIT 2.05.364.0000 SPICER 1500**

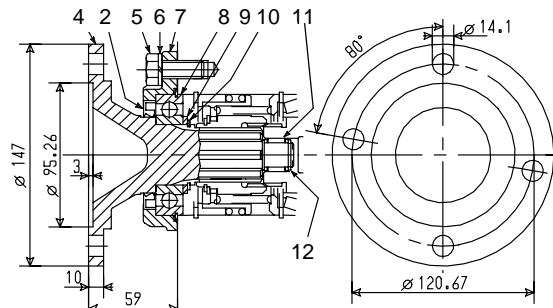

REF.	CODE	DESCRIPTION	QT.
7	1.09.01.037.00	Support	1
8	0.10.01.005.00	Bearing 6208-NR	1
9	1.26.01.026.00	Spacer 206E/20	1
10	0.07.01.002.00	Circlip 40e UNI 7435	1
11	0.10.06.001.00	Needle cage K16x22x16	1
12	0.07.04.004.00	Circlip WR16	1



**KIT 2.05.426.0000 Adaptor for 2/4 bolt SAE C 2/4 pumps, splined shaft**

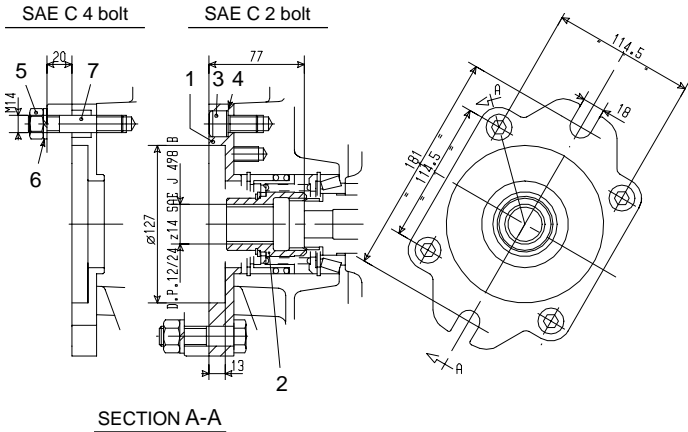

REF.	CODE	DESCRIPTION	QT.
1	1.07.01.162.00	Flange	1
2	1.17.02.073.00	Splined sleeve	1
3	0.01.03.084.00	Capscrew TCEI M14x25 UNI 5931 CL RES 8.8	4
4	0.04.04.005.00	Washer Schnorr 14	4
5	0.03.01.017.00	Hex nut M14 UNI 5588 CL RES 10	4
6	0.04.02.010.00	Lockwasher 15 UNI 1751	4
7	0.02.02.052.00	Stud M14x55 UNI 5911	4
8	0.07.02.048.00	Circlip J80x2,5V	1

**KIT 2.05.427.0000 Adaptor for 2/4 bolt SAE C-C pumps, splined shaft 12/24 17 T**

**KIT 2.05.489.0000 Adaptor for 2/4 bolt SAE C pumps, splined shaft 16/32 21 T**

**KIT 2.05.490.0000 Adaptor for 2/4 bolt SAE C pumps, splined shaft 16/32 23 T**

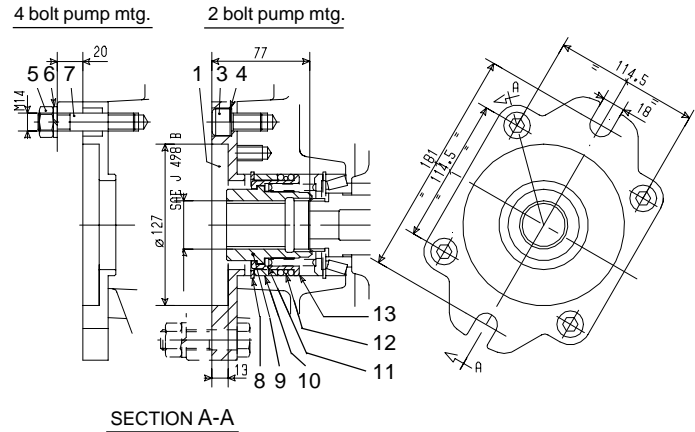

REF.	CODE	DESCRIPTION	QT.
9	1.17.02.095.00	Splined sleeve 12/24 17T SAE J498B (kit 2.05.427)	1
	1.17.02.109.00	Splined sleeve 16/32 21T SAE J498B (kit 2.05.489)	1
	1.17.02.110.00	Splined sleeve 16/32 23T SAE J498B (kit 2.05.490)	1
10	1.27.02.142.00	Ring	1
11	1.27.02.081.00	Washer 64,8x53x3	1
12	0.08.02.135.00	O-Ring OR 4250 Viton	1
13	1.21.02.027.00	Piston	1

**ADAPTOR KITS FOR 3.2.90.3 / 4 / 5 / 6 SPLIT-SHAFT UNIT ONLY**

**KIT 2.05.428.0000 Adaptor for 4 bolt SAE D pumps, splined shaft**

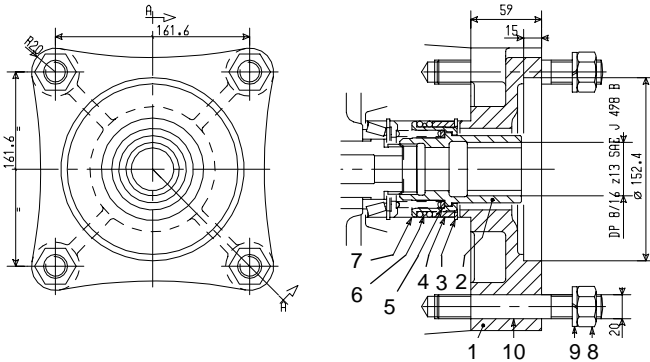

REF.	CODE	DESCRIPTION	QT.
1	1.07.01.163.00	Flange	1
2	1.17.02.096.00	Splined sleeve	1
3	0.07.02.048.00	Circlip J80x2,5V	1
4	1.27.02.142.00	Ring	1
5	1.27.02.081.00	Washer 64,8x53x3	1
6	0.08.02.135.00	O-Ring OR 4250 Viton	1
7	1.21.02.027.00	Piston	1
8	0.03.01.018.00	Hex nut M20 UNI 5588 CL RES 10	4
9	0.04.02.011.00	Lockwasher 20 UNI 1751	4
10	1.30.01.087.00	Stud M20x110	4

**ADAPTOR KITS FOR 3.2.90.3 / 4 SPLIT-SHAFT UNIT**

**KIT 3.5.2.053.0000 (with circuit breaker 4.2.00.01) Adaptor for Group 2 industrial pumps on the idler shaft**

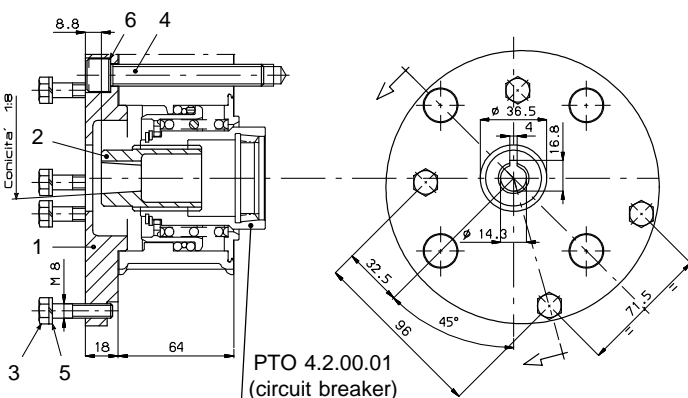

REF.	CODE	DESCRIPTION	QT.
1	1.07.01.146.00	Flange	1
2	1.17.02.082.00	Splined sleeve	1
3	0.01.01.021.00	Capscrew TE M8x35 UNI 5739 CL RES 8.8	4
4	0.01.03.079.00	Capscrew TCEI M12x85 UNI 5931 CL RES 8.8	4
5	0.04.02.002.00	Lockwasher 8,4 UNI 1751	4
6	0.04.04.002.00	Washer Schnorr ø 12	4

## ADAPTOR KITS FOR 3.2.90.1 / 2 / 3 / 4 / 5 / 6 SPLIT-SHAFT UNIT

### KIT 3.5.2.055.0000 3 bolt PZB pump adaptor flange

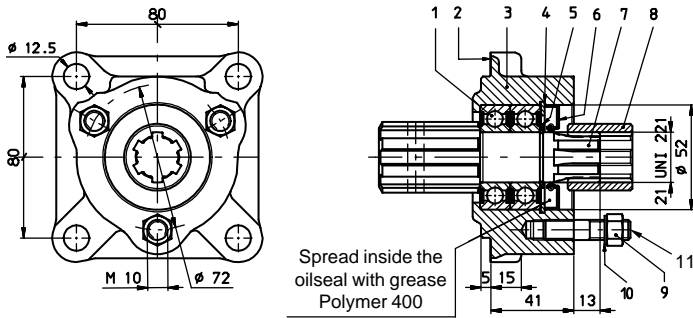

### KIT 3.5.2.037.0000 Adaptor for Group 2 industrial pumps on ISO 4 bolt PTO's

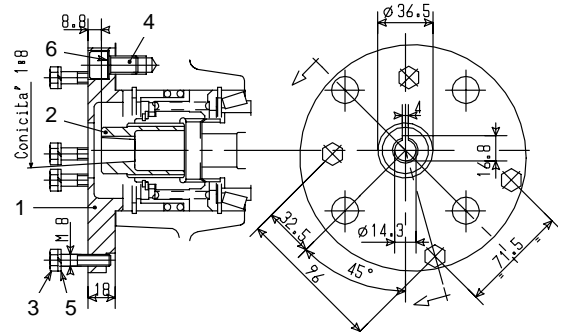

REF.	CODE	DESCRIPTION	QT.
1	0.10.01.017.00	Bearing 6205-2RS	2
2	1.29.01.013.00	Gasket 735A/6	1
3	1.09.01.054.00	Support	1
4	0.07.02.004.00	Circlip 52i UNI 7437	1
5	0.07.01.005.00	Circlip 25e UNI 7435	1
6	0.08.01.104.00	Seal	1
7	1.13.01.174.00	Shaft	1
8	1.17.01.001.00	Splined sleeve mod.12	1
9	1.30.02.001.00	Hex nut M10 hexag. 14 CL RES 6S	3
10	0.04.08.001.00	Lockwasher 10,5 DIN 7980	3
11	0.02.02.017.00	Stud M10x28 UNI 5911	3

REF.	CODE	DESCRIPTION	QT.
1	1.07.01.146.00	Flange	1
2	1.17.02.082.00	Splined sleeve	1
3	0.01.01.021.00	Capscrew TE M8x35 UNI 5739 CL RES 8.8	4
4	0.01.03.077.00	Capscrew TCEI M12x20 UNI 5931 CL RES 8.8	4
5	0.04.02.002.00	Lockwasher 8,4 UNI 1751	4
6	0.04.04.002.00	Washer Schnorr 12	4