

3-WAY, 3-POSITIONS VALVE

3.3.1.036.00.00

3-WAY, 2-POSITIONS VALVE

3.3.1.046.00.00



- ✓ The air operated **3.3.1.036** diverter valve allows **two hydraulic systems** (e.g. tipping truck and/or trailer) **to be controlled separately and/or together.**
- ✓ The air operated **3.3.1.046** diverter valve allows **two hydraulic systems** (e.g. crane/tipper, truck/trailer) **to be controlled separately.**

Three positions air controlled valve (pump, tractor, trailer)
2 or 3 positions.

Oil flow up to 250 litres/min.

Oil pressure max.: 350 Bar.

Air pressure 4,5 - 10 Bar (3.3.1.036 valve)

Air pressure 4,5 - 12 Bar (3.3.1.046 valve)

WEIGHT: kg. 4,5

CODE 3.3.1.036.000 3-WAY, 3-POSITIONS

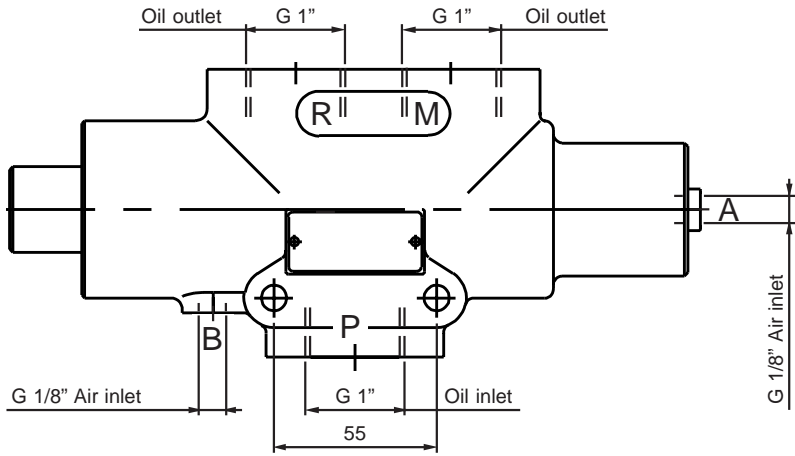

NO AIR TO "A" and "B" P → M
 (truck only)

AIR TO "A" P → R
 (trailer only)

AIR TO "B" P → M + R
 (truck and trailer together)

AIR CONTROL SYSTEM WITH DIVERTER VALVE FOR SEPARATE AND SIMULTANEOUS OPERATION IN A TIPPING TRUCK AND TRAILER RIG OR IN A SEMITRAILER WITH TWO TIPPING BODIES

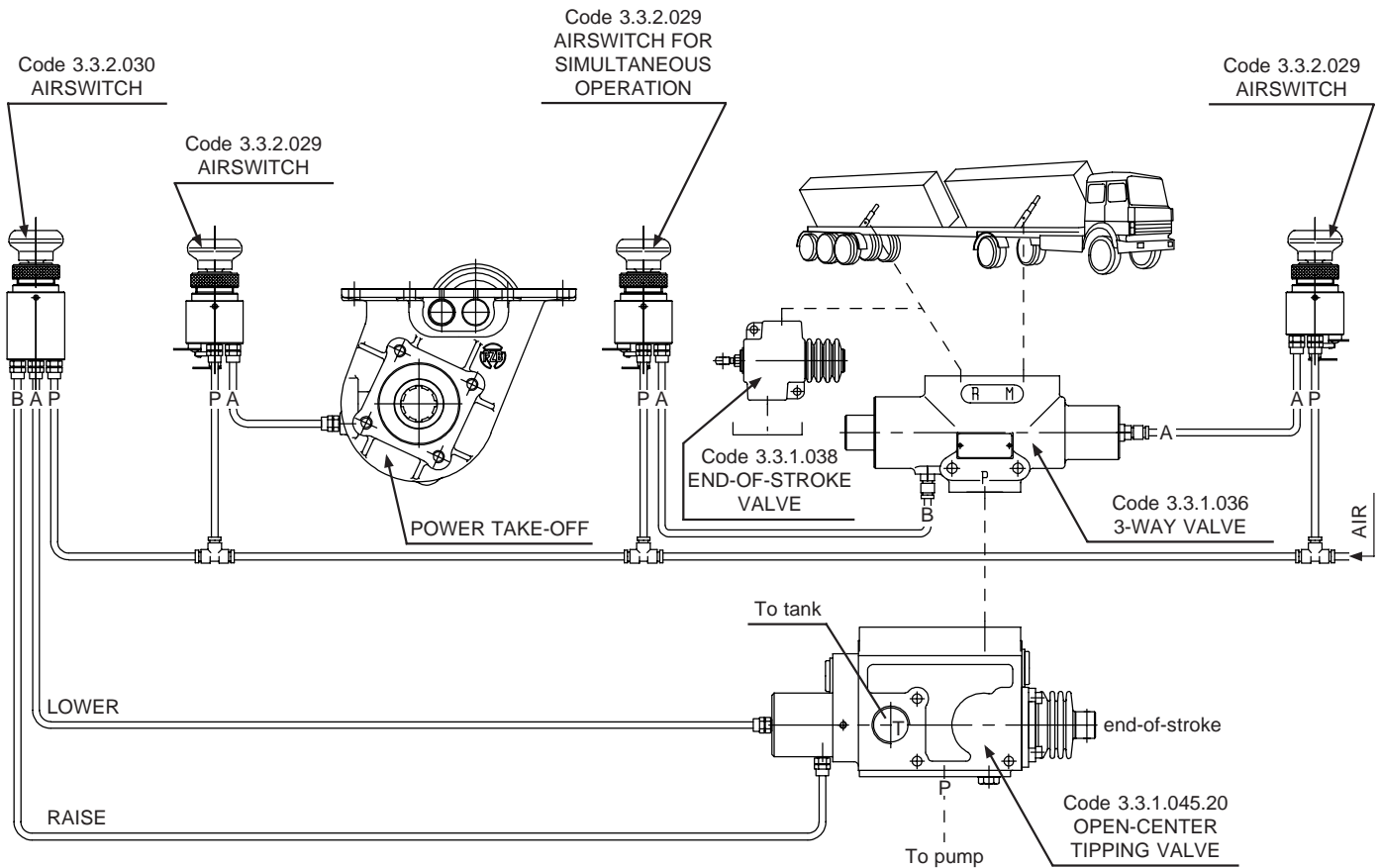

CODE 3.3.1.046.000 3-WAY, 2-POSITIONS

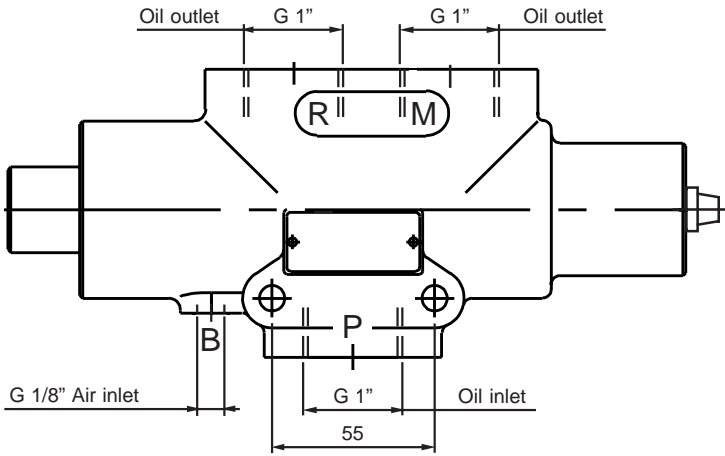

NO AIR TO "B"
(truck only) P → M

AIR TO "B"
(trailer or crane only) P → R

AIR CONTROL SYSTEM WITH DIVERTER VALVE FOR SEPARATE TIPPING OPERATION IN A TRUCK AND TRAILER RIG

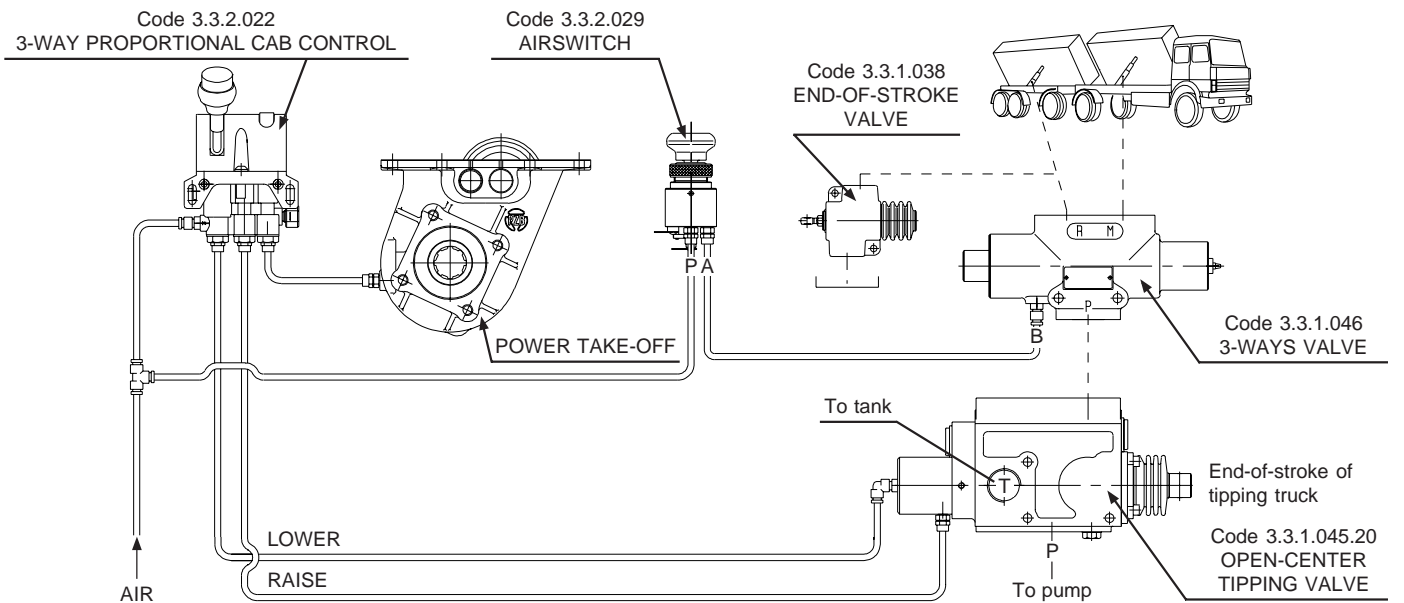

AIR CONTROL SYSTEM WITH DIVERTER VALVE IN A TIPPER-CRANE VEHICLE

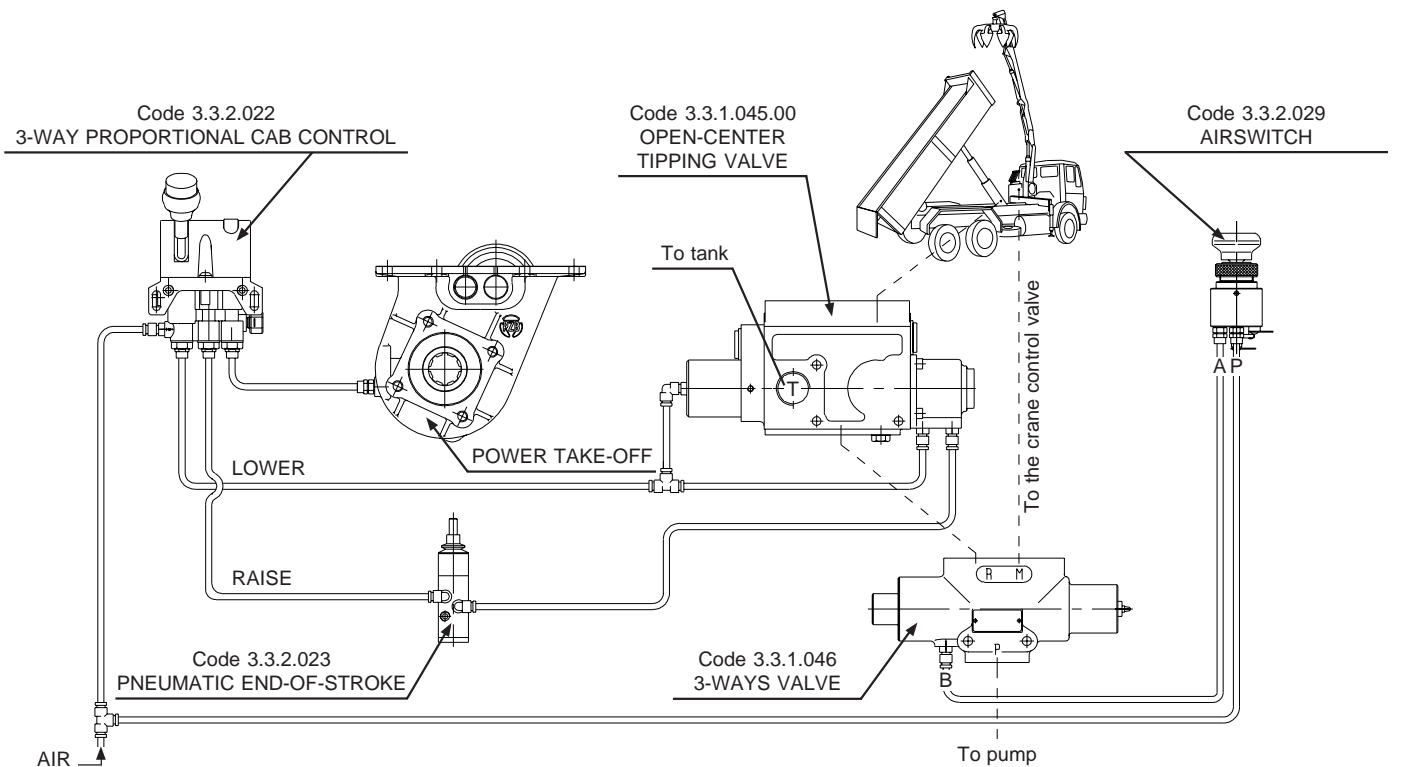

VERSION 3.3.1.036.0000

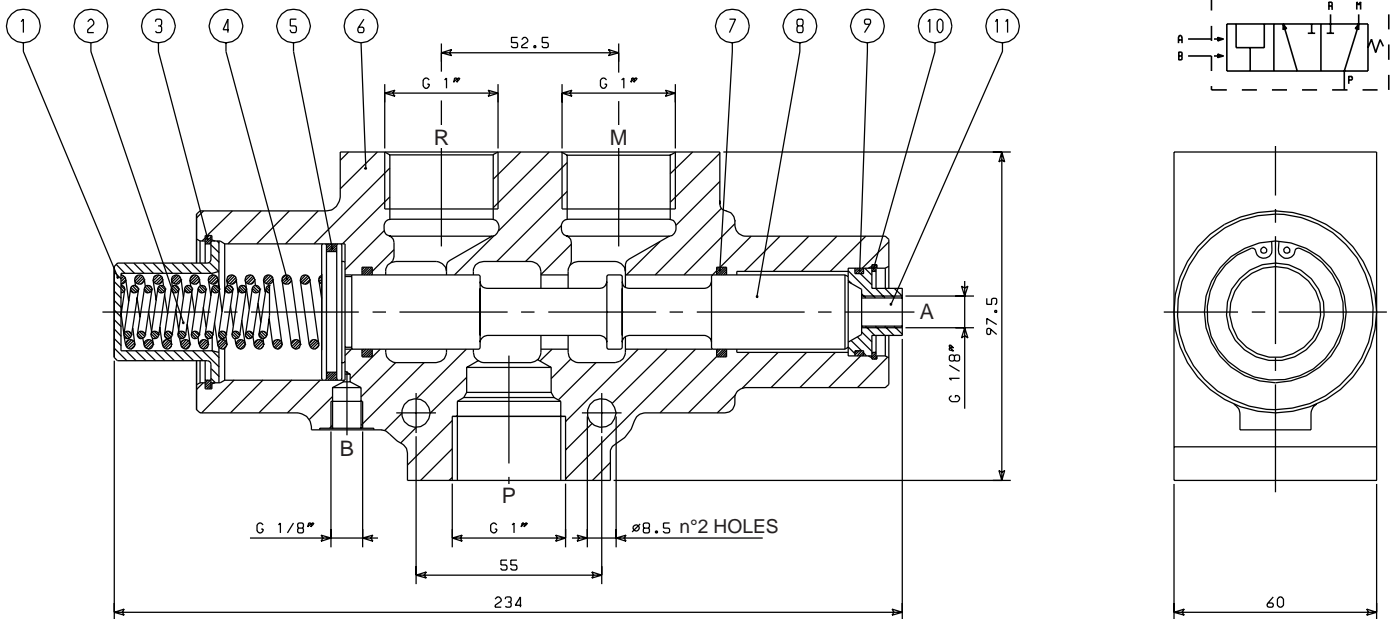

REF.	CODE	DESCRIPTION	QT.
1	1.24.01.084.00	Cover	1
2	1.28.01.104.00	Coil spring	1
3	0.07.02.008.00	Circlip 42i UNI 7437	1
4	1.28.01.091.00	Coil spring	1
5	0.08.02.024.00	O-Ring OR 3137	1
6	1.06.01.019.00	Valve body	1

REF.	CODE	DESCRIPTION	QT.
7	0.08.02.083.00	O-Ring OR 3087	2
8	1.15.00.054.00	Valve spool	1
9	0.08.02.067.00	O-Ring OR 2087	1
10	0.07.02.034.00	Circlip 26i UNI 7437	1
11	1.24.01.067.00	Cover	1

VERSION 3.3.1.046.0000

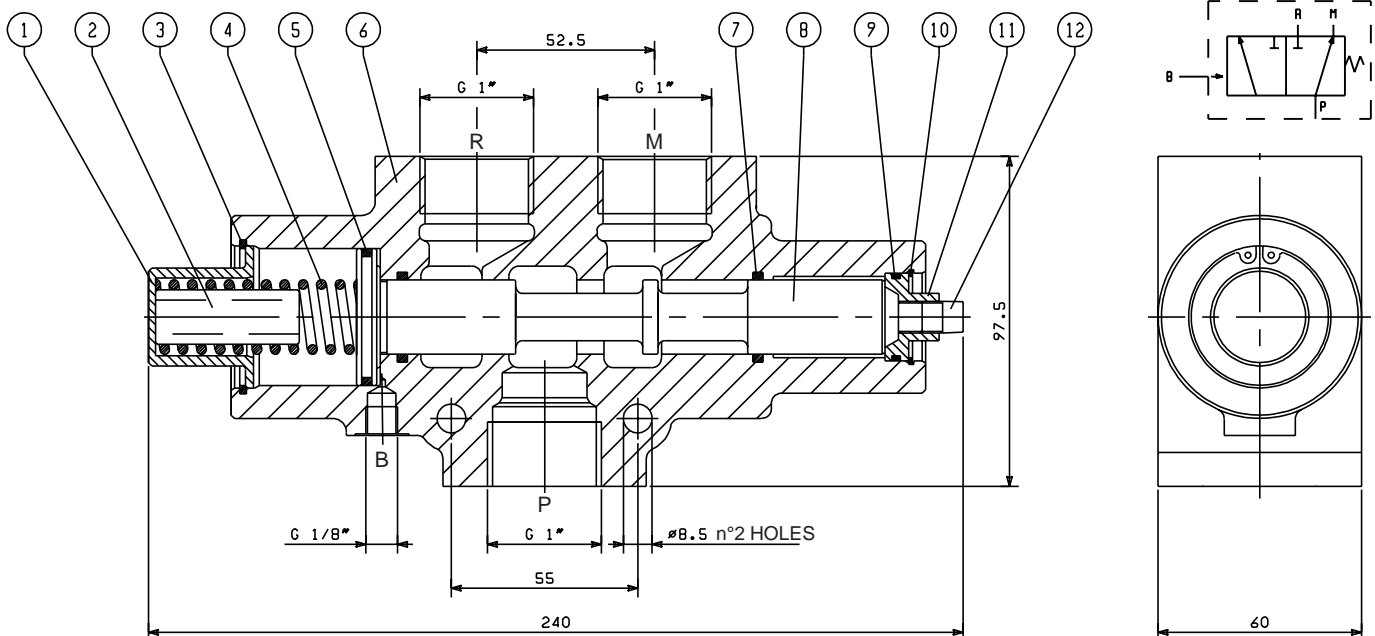

REF.	CODE	DESCRIPTION	QT.
1	1.24.01.084.00	Cover	1
2	1.26.01.108.00	Spacer	1
3	0.07.02.008.00	Circlip 42i UNI 7437	1
4	1.28.01.091.00	Coil spring	1
5	0.08.02.024.00	O-Ring OR 3137	1
6	1.06.01.019.00	Valve body	1

REF.	CODE	DESCRIPTION	QT.
7	0.08.02.083.00	O-Ring OR 3087	2
8	1.15.00.054.00	Valve spool	1
9	0.08.02.067.00	O-Ring OR 2087	1
10	0.07.02.034.00	Circlip 26i UNI 7437	1
11	1.24.01.067.00	Cover	1
12	0.99.00.159.00	Silencer G1/8 1st	1